



axil

Irreversible electromechanical actuator

for swing gates with leaves up to 2.8 m in length

Available in two versions: 24V and 230V



axil PLUS

- All the models in the Axil range are fitted with opening mechanical limit stop
- Practical wiring compartment
- Internal start capacitor
- Versions with encoder for accurate and safe operation
- Version with electrical limit switch in opening
- 24V version for intensive use

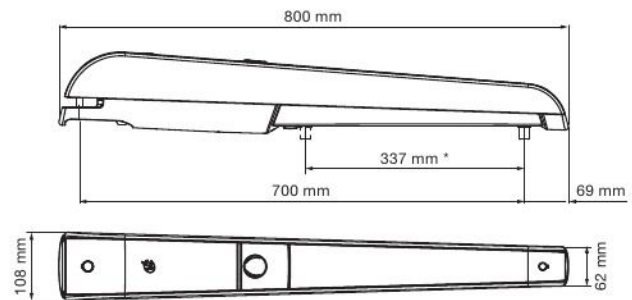

TECHNICAL FEATURES

Description	230V opening mechanical stop	230V opening electrical limit switch	230V encoder	24V encoder
MODEL	AXIL	AXIL-FC	AXIL-ECD	AXIL-24V
CODE	22J001	22J002	22J003	22J005
Maximum leaf length (m)	2.8	2.8	2.8	2.8
Maximum leaf weight (Kg)	300	300	300	300
Power supply (Vac - Hz)	230 - 50	230 - 50	230 - 50	24 Vdc
Idling current (A)	0.8	0.8	0.8	1.0
Full load current (A)	1.1	1.1	1.1	8.0
Motor power (W)	230	230	230	200
Capacitor (µF)	6.3	6.3	6.3	-
Maximum travel (mm)	350	350	350	350
Operating speed (m/s)	0.016	0.016	0.016	0.02 - 0.012
Maximum thrust (N)	1700	1700	1700	1700
Working temperature (°C)	-30 ÷ +55	-30 ÷ +55	-30 ÷ +55	-30 ÷ +55
Protection degree (IP)	44	44	44	44
Duty cycle (%)	35	35	35	60
Motor weight (Kg)	7.5	7.5	7.5	7.5

CONTROL UNITS TO BE USED

M
230V



M
230V



M
230V



CITY1

Digital control unit for 230V motors

FLEXY2

Analogue control unit for 230V motors

CITY11

Analogue control unit for 230V motors.
Output for 12V electrolock

M
24V



CITY2+L

Digital control unit for 24V motors

ACCESSORIES



162223

Closing mechanical stop

162224

Front screw bracket

162225

Rear screw bracket

ACC009

Warning sign



axil kit

Installation kit for swing gates
with leaves up to 2.8 m long

Available with 24V and 230V motors

COMPOSITION



1 Irreversible electromechanical actuator



2 CITY1
Digital control unit for 230V motors



2 CITY2+L
Digital control unit for 24V motors



3 PHOX2
433.92MHz rolling code transmitter



4 MR2
Plug-in module receiver



5 SENSIVA-XS
Miniaturized wall-mounted and pillar-mounted photocells



6 LUMOS-M
Led flashing light



7 ACC009
Warning sign

ASSEMBLY DIAGRAM

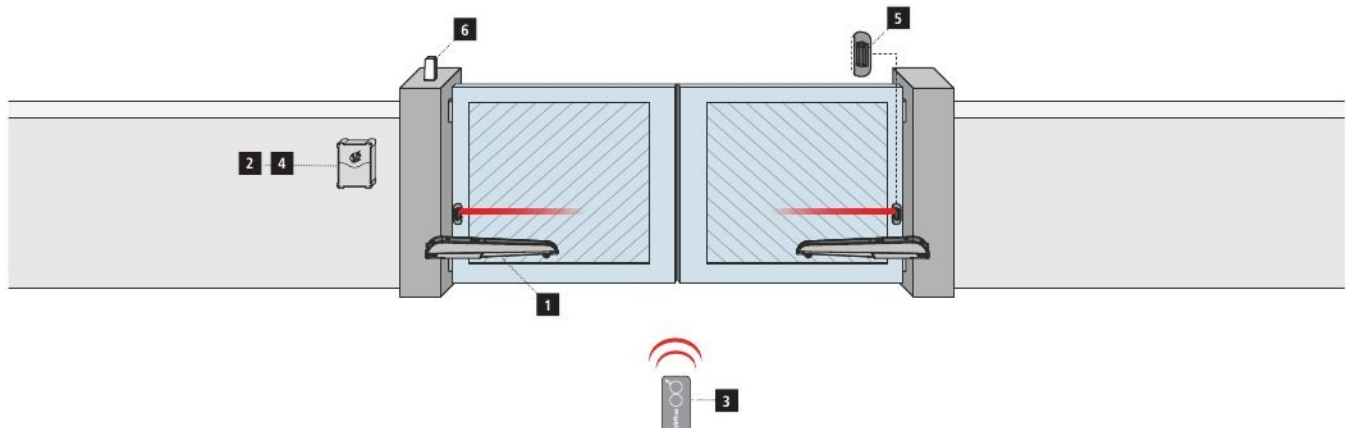

To complete the installation with other additional accessories refer to the example system at the beginning of the section



TECHNICAL FEATURES

Description	230V opening mechanical stop	24V encoder
MODEL	AXIL	AXIL-24V
CODE	22J001	22J005
Maximum leaf length (m)	2.8	2.8
Maximum leaf weight (Kg)	300	300
Power supply (Vac - Hz)	230 - 50	24 Vdc
Idling current (A)	0.8	1.0
Full load current (A)	1.1	8.0
Motor power (W)	230	200
Capacitor (µF)	6.3	-
Maximum travel (mm)	350	350
Operating speed (m/s)	0.016	0.02 - 0.012
Maximum thrust (N)	1700	1700
Working temperature (°C)	-30 ÷ +55	-30 ÷ +55
Protection degree (IP)	44	44
Duty cycle (%)	35	60
Motor weight (Kg)	7.5	7.5

MOTORS FOR SWING GATES

	Kit MODEL ▼	 CONTROL UNIT	 PHOX2	 MR2	 SENSIVA-XS	 LUMOS-M	 ACC009	Kit CODE ▼
230V	Kit Light AXIL-230V	CITY1	■ ■	■				29F017
	Kit Full AXIL-230V	CITY1	■ ■	■	■	■	■	29F018
24V	Kit Light AXIL-24V	CITY2+L	■ ■	■				29F015
	Kit Full AXIL-24V	CITY2+L	■ ■	■	■	■	■	29F016